

mod. PENDENT

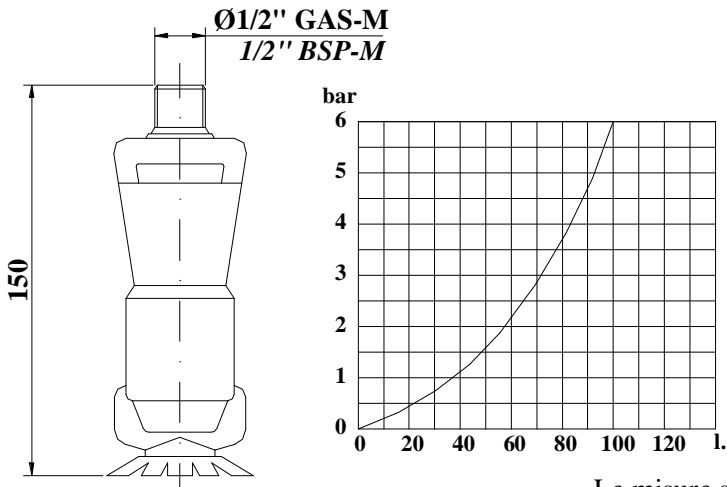

mod. UPRIGHT

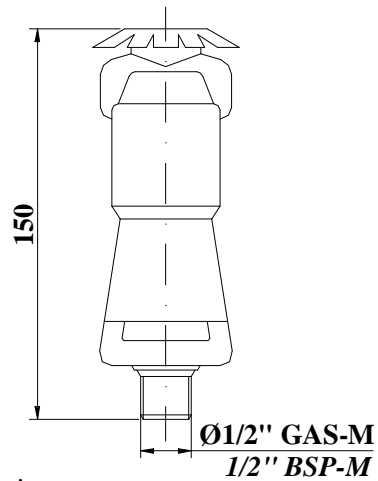

Le misure sono in mm
Dimensions are in mm

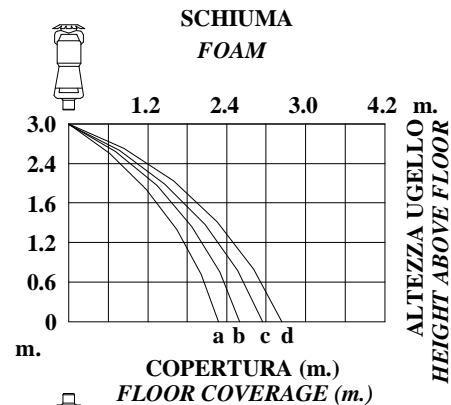
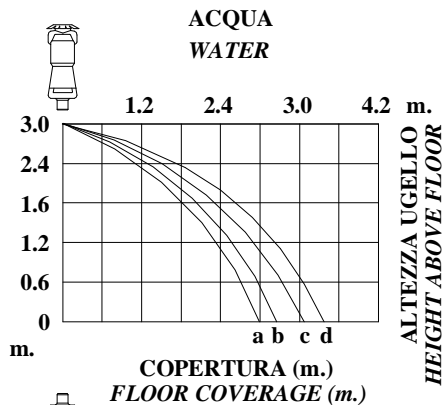

a = 2 bar
b = 3 bar
c = 4.5 bar
d = 6 bar

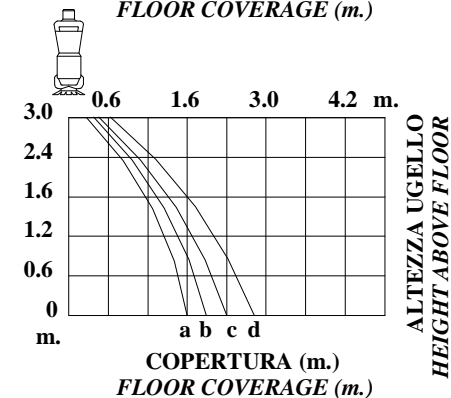
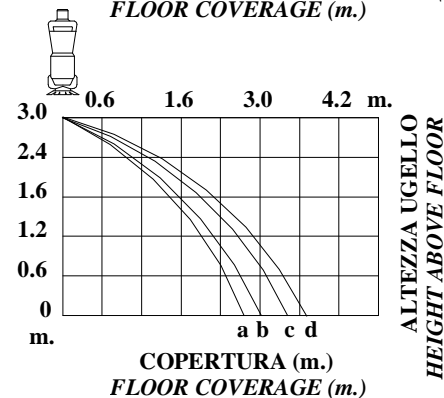

CARATTERISTICHE TECNICHE

- Corpo: bronzo
- Peso: 551 g
- Fattore K: 41.2
- Rapporto d'espansione: 1/6 ^{(1) (2)}

A RICHIESTA

- Connessioni diverse
- Portate diverse

CONSTRUCTION FEATURES

- Body material: bronze
- Weight: 551 g
- K factor: 41.2
- Expansion ratio: 1/6 ^{(1) (2)}

OPTIONAL

- Different connections
- Different flow rates

⁽¹⁾ Il rapporto di espansione è inteso con aria pulita, salvo diversa indicazione del produttore di schiumogeno.

⁽²⁾ Dipende dal tipo di schiumogeno.

⁽¹⁾ The expansion ratio understands with fresh air, or different indication of foam producer.

⁽²⁾ Depending on foam concentrate type.