

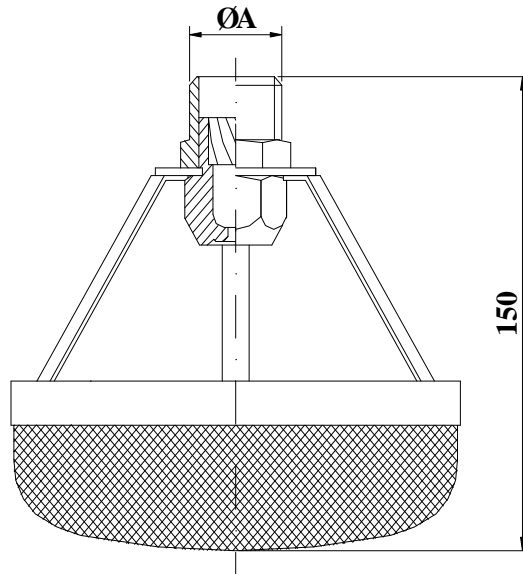

Certified



Le misure sono in mm  
Dimensions are in mm

UME-27

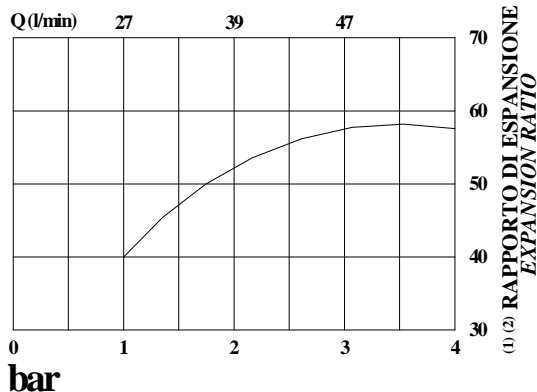

UME-45

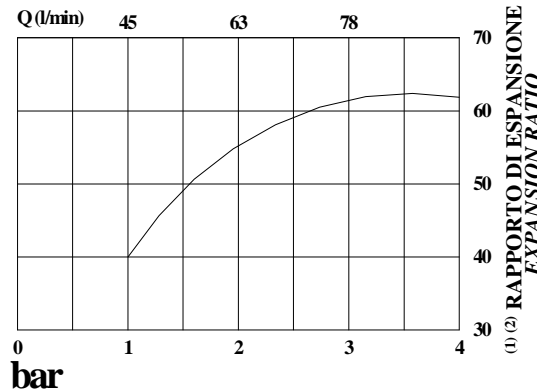

#### CARATTERISTICHE COSTRUTTIVE

- Corpo in acciaio inox AISI 316
- Ugello in ottone

#### CONSTRUCTION FEATURES

- Body material: stainless steel AISI 316
- Nozzle material: brass

| MODELLO<br>MODEL | FATTORE K<br>K FACTOR | Ø A<br>GAS - BSP | PESO<br>WEIGHT<br>Kg |
|------------------|-----------------------|------------------|----------------------|
| UME-27           | K = 27                | ¾" - M           | 0.7                  |
| UME-45           | K = 45                | 1" - M           | 0.75                 |

(1) Il rapporto di espansione è inteso con aria pulita, salvo diversa indicazione del produttore di schiumogeno.

(2) Dipende dal tipo di schiumogeno.

(1) The indicated expansion ratio is obtained with fresh air, except of different indication of foam producer.

(2) Depending on foam concentrate type.